

DIGITAL INDOOR CLOCK

ECO-DC

The ECO-DC series are digital clocks in 7 segment LED technique at an economical price, designed in an elegant and slim case, for time, date or alternating time/date display.



5 STEPS TO YOUR ECO-DC

To make sure your digital clock meets all your requirements, you can assemble the components individually. Choose from various sizes, colors, and display variants, as well as installation options and additional options. Configure your ECO-DC according to your wishes, suitable for rooms and general conditions. Our experts will be happy to help you if you have questions.

1.

Define your display type and digit height

FORMAT

You have the choice. Display type, digit size, and number of digits offer multiple variations. The reading distance varies depending on the color, lighting, viewing angle, etc. The order code is composed as follows:

Digit height	10:08	10:08 25	10:08:25	Reading distance
57 mm	57.4	57.6	57x.6	25–30 m
75 mm	75.4	75.6	75x.6	30–40 m
100 mm	100.4	100.6	100x.6	40–60 m

2.

Choose your display color

DISPLAY COLOR

The display background is black, offering optimal display contrast with a viewing angle of 160 degrees. The digit color is selectable. The available variants:

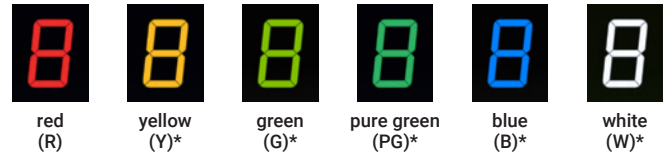

* not available for ECO-DC.57x.6, ECO-DC.100x.6

3.

Which installation solution works?

INSTALLATION SOLUTION

Choose the one- or double-sided solution and pick a fitting installation option.



N.N
Wall mounting single-sided



N.S
Ceiling suspension single-sided



N.B
Wall bracket mounting single-sided

D.S
Ceiling suspension double-sided

D.B
Wall bracket mounting double-sided

4. Which time code do you need?

SYNCHRONIZATION

The ECO-DC is designed for all common synchronization types, and is also a good solution as a supplement to existing systems.

CODE	SYNCHRONIZATION	POWER SUPPLY
MBL	MOBALine	Mains
MBLDCF	MOBALine / DCF active	Mains
IRIG	IRIG-B	Mains
NTP	NTP	Mains
PoE	NTP	PoE
WiFi	WiFi (2.4 GHz), NTP	Mains

YOUR ECO-DC CLOCK IS COMPLETE

You can now order your ECO-DC and calculate the corresponding code. Enter the abbreviation for each component of your choice in the bright field and find your product code. It can be used immediately as an order code.

My ECO-DC clock ECO-DC.

1. Format Code

2. Display color Code

3. Installation solution Code

4. Synchronization Code

5. Option Code

Example order code



	1.	2.	3.	4.	5.
ECO-DC.	57.4.	R.	N.N.	NTP.	
ECO-DC	digit height 57mm	red display	wall mounting, single-sided	Ethernet version	no option

5. Want additional options?

OPTIONS

On request, the ECO-DC can be equipped with the following additional features:

CODE	OPTION
VDC	Power supply via 18–56 VDC ¹
SL	SMD diode display
E	Support for temperature, stopwatch and IR remote control functions ²
IP 32	IP 32 safety rating
IP 40	IP 40 safety rating ³

¹ not available for PoE version
² simultaneous use of a temperature sensor (TP) and a wired stopwatch control keyboard (SK) is not possible
³ cannot be combined with option E

Do you need accessories?

ACCESSORIES

Whether high-precision synchronization from satellite or radio, convenient operation, or temperature display – you can find the right accessories for your clock here.

CODE	ACCESSORY
IR	remote IR controller
SK	keyboard for clock and stopwatch control, cable 5m, handheld
TP 3m	temperature sensor, IP 66, cable 3m ¹
TP 30m	temperature sensor, IP 66, cable 30m ¹
TP RS485	temperature sensor with RS 485 interface, power supply 12 VDC, cable between sensor and interface 3 m (for SI version only) ¹
TP LAN	temperature sensor with Ethernet interface, power supply 5 VDC, cable between sensor and interface 3 m (for NTP, PoE and WiFi version only) ¹

¹ only for clocks with option E

TECHNICAL DATA

TECHNICAL DATA		ECO-DC.57.4	ECO-DC.57.6	ECO-DC.57x.6	ECO-DC.75.4	ECO-DC.75.6	ECO-DC.75x.6	ECO-DC.100.4	ECO-DC.100.6	ECO-DC.100x.6
Digit height (mm)		57	57/38	57	75	75/57	75	100	100/57	100
Time format		HH:MM	HH:MM ^{SS}	HH:MM:SS	HH:MM	HH:MM ^{SS}	HH:MM:SS	HH:MM	HH:MM ^{SS}	HH:MM:SS
Display features		Time display in 12-hour or 24-hour format Alternating display of time, date and temperature (in C° or F°, with external temperature sensor connected) ¹ Automatic or manual display brightness adjustment Stopwatch (count up to 24 hours, countdown from set value, display of time intervals, freezing of display...) ¹ Stopwatch operation via push buttons, IR remote control ¹								
Material		Housing: plastic Cover glass: anti-reflective plexiglass								
Power supply		Standard: 100 – 240 VAC, 50 – 60 Hz VDC (option, not for PoE version): 24 VDC PoE version: PoE (IEEE 802.3af class 0)								
Power consumption	SS	7 VA	8 VA	8 VA	7 VA	8 VA	8 VA	7 VA	8 VA	10 VA
	DS	11 VA	16 VA	16 VA	11 VA	16 VA	16 VA	11 VA	16 VA	18 VA
	SS PoE	7 VA	8 VA	8 VA	7 VA	8 VA	8 VA	7 VA	8 VA	10 VA
	DS PoE	11 VA	15 VA	15 VA	11 VA	15 VA	15 VA	11 VA	15 VA	15 VA
Quartz accuracy at 20 °C		without synchronization: ±0.3 seconds/day								
Quartz-based time maintenance (without power supply)		> 12 hours from supercapacitor								
Temperature precision		-25 to +85 °C: ±0.5 °C, -50 to +125 °C: ±2.0 °C								
Operating conditions		-5 to +55 °C (0 to 95% relative humidity, non-condensing)								
Degree of protection		IP 30, optionally IP 40								
Standards		2002/96/EC / 2011/65/EU / 2014/30/EU / 2014/35/EU / EN 50121-4 / EN 55022 / EN 55024 / EN 60950-1								
Weight (kg)	SS	0.75	1.15	1.25	1.25	1.6	1.8	1.8	1.9	2
	DS	2	2.8	3	3	3.7	4.1	4.1	4.3	4.5
Dimensions (in mm, see below)	A	341						580		
	B	122						180		
	C	44						53		
	D	292						520		
	E	104						150		
	F	275						520		
	G	99						120		
	H	52						60		

SS = single-sided; DS = double-sided
¹ only with option E

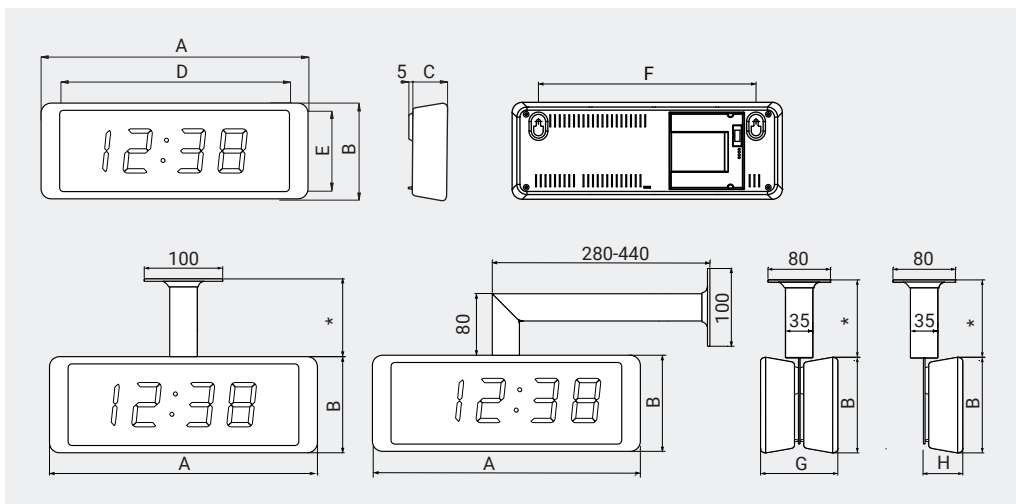

LE-800683.23 / 2021

*Have questions?
 We are happy to help.*

Moser-Baer AG | Spitalstrasse 7 | CH-3454 Sumiswald
 Tel. 034 432 46 46 | Fax 034 432 46 99
 info@mobatime.com | www.mobatime.com

